

Versuch mit R und C mit Oszi

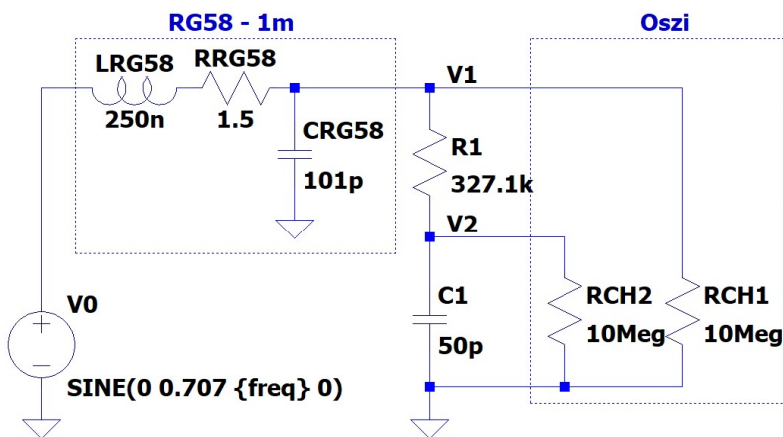

```
.tran 0 500u 200u 0.1u
.param freq=10000
.meas TRAN vr PP V(V1,V2)
.meas TRAN vc PP V(V2)
.meas TRAN tr FIND time WHEN V(V1,V2)=0 FALL=1
.meas TRAN tc FIND time WHEN V(V2)=0 FALL=1
.meas TRAN tv FIND time WHEN V(V1)=0 FALL=1
.meas TRAN delayr PARAM tr-tv
.meas TRAN delayc PARAM tc-tv
.meas TRAN phaser PARAM delayr*freq*360
.meas TRAN phasec PARAM delayc*freq*360
```

```
vr: PP(V(V1,V2)) = 0.997877171263
vc: PP(V(V2)) = 0.970532409745
tr: time = 3.79651318291e-05
tc: time = 6.24605775778e-05
tv: time = 5.00005064151e-05
delayr: tr-tv = -1.2035374586e-05
delayc: tc-tv = 1.24600711627e-05
phaser: delayr*freq*360 = -43.3273485095
phasec: delayc*freq*360 = 44.8562561857
```

$$R1 := 327,1 \text{ k}\Omega$$

$$C1 := 50 \text{ pF}$$

$$F0 := \frac{1}{2 \cdot \pi \cdot R1 \cdot C1} = 9731,2714 \text{ Hz}$$

$$\omega0 := 2 \cdot \pi \cdot F0 = 61143,3812 \text{ Hz}$$

$$T0 := \frac{1}{F0} = 0,1028 \text{ ms}$$

$$ZC1 := \frac{i}{\omega0 \cdot C1} = 327,1 \cdot i \text{ k}\Omega$$

$$ZLRG58 := \omega0 \cdot 250 \text{ nH} \cdot i = 15,2858 \cdot i \text{ m}\Omega$$

$$RRG58 := 1,5 \Omega$$

$$ZCRG58 := \frac{i}{\omega0 \cdot 101 \text{ pF}}$$

$$RCH1 := 10 \text{ M}\Omega$$

$$RCH2 := RCH1$$

$$ZC1RCH2 := \frac{ZC1 \cdot RCH2}{ZC1 + RCH2} = (0,0107 + 0,3268 \cdot i) \text{ M}\Omega$$

$$ZCH := \frac{(ZC1RCH2 + R1) \cdot RCH1}{ZC1RCH2 + R1 + RCH1} = (0,3364 + 0,3054 \cdot i) \text{ M}\Omega$$

$$Zg2 := \frac{ZCRG58 \cdot ZCH}{ZCRG58 + ZCH} = (0,0266 + 0,125 \cdot i) \text{ M}\Omega$$

$$Zg := ZLRG58 + RRG58 + Zg2 = (0,0266 + 0,125 \cdot i) \text{ M}\Omega$$

$$phase := \arg(Zg) = 77,983^\circ$$

$$V0pp := \sqrt{2} \text{ V} = 1,4142 \text{ V}$$

$$\varphi_v := 90^\circ$$

$$V0(t) := \frac{V0pp}{2} \cdot e^{i \cdot (\omega0 \cdot t + \varphi_v)}$$

$$I_g(t) := \frac{V0(t)}{Zg}$$

$$VRG58(t) := I_g(t) \cdot (ZLRG58 + RRG58)$$

$$V1(t) := V0(t) - VRG58(t)$$

$$ICRG58(t) := \frac{V1(t)}{ZCRG58} \quad IRCH1(t) := \frac{V1(t)}{RCH1}$$

$$VR1(t) := (IR1(t) \cdot R1)$$

$$IR1(t) := I_g(t) - ICRG58(t) - IRCH1(t)$$

$$V2(t) := V1(t) - VR1(t)$$

$$IC1(t) := IR1(t) - \frac{V2(t)}{ZC1RCH2}$$

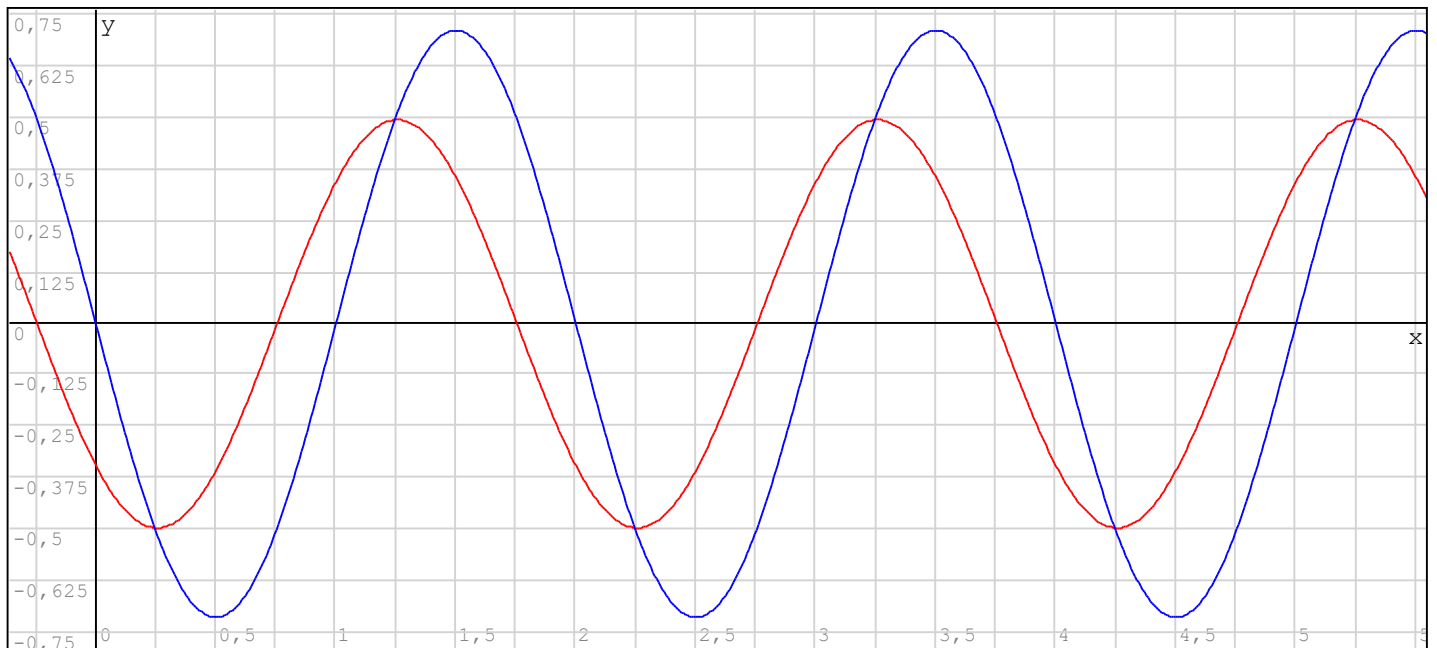

$$\begin{cases} \operatorname{Re} \left(V1 \left(x \cdot \frac{T0}{2} \right) \right) \\ \operatorname{Re} \left(V2 \left(x \cdot \frac{T0}{2} \right) \right) \end{cases}$$

$$V1(0) = \left(-8,1016 \cdot 10^{-6} + 0,7071 \cdot i \right) \text{ V}$$

$$V2(0) = \left(-0,3422 + 0,3534 \cdot i \right) \text{ V}$$

$$dV1dt(t) := \frac{d}{dt} V1(t)$$

$$dV2dt(t) := \frac{d}{dt} V1(t) - \frac{d}{dt} VR1(t)$$

$$dV1dt(0) = \left(-43234,7888 - 0,4954 \cdot i \right) \frac{\text{V}}{\text{s}}$$

$$dV2dt(0) = \left(-21605,9621 - 20922,0957 \cdot i \right) \frac{\text{V}}{\text{s}}$$

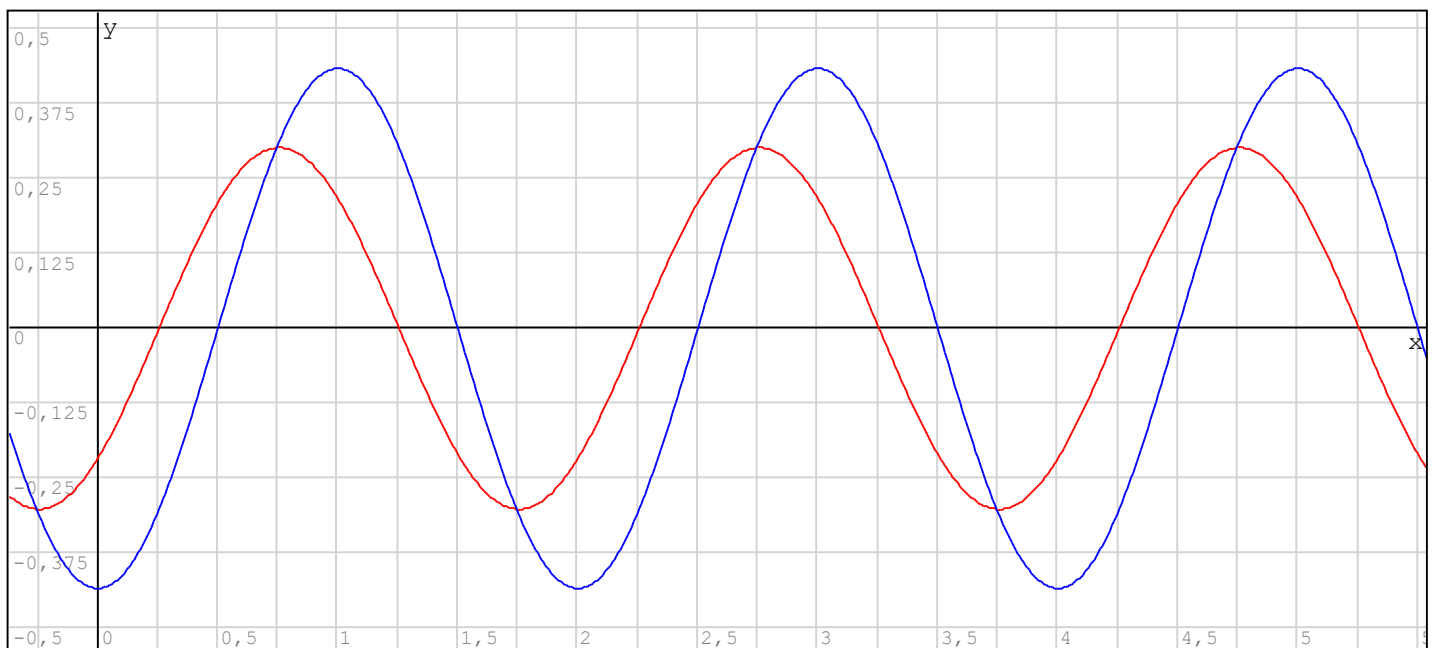

$$\begin{cases} 10^{-5} \cdot \operatorname{Re} \left(dV1dt \left(x \cdot \frac{T0}{2} \right) \right) \\ 10^{-5} \cdot \operatorname{Re} \left(dV2dt \left(x \cdot \frac{T0}{2} \right) \right) \end{cases}$$

Startwerte zur Nullstellensuche

$$\operatorname{Re} \left(V1 \left(3,00 \cdot \frac{T0}{2} \right) \right) = 8,1016 \cdot 10^{-6} \text{ V}$$

$$\operatorname{Re} \left(dV1dt \left(2,5 \cdot \frac{T0}{2} \right) \right) = 0,4954 \frac{\text{V}}{\text{s}}$$

$$\operatorname{Re} \left(V2 \left(2,75 \cdot \frac{T0}{2} \right) \right) = -0,0079 \text{ V}$$

$$\operatorname{Re} \left(dV2dt \left(2,25 \cdot \frac{T0}{2} \right) \right) = -483,5666 \frac{\text{V}}{\text{s}}$$

Nullstellensuche

Clear(xV1) = 1

$$LV1 := \operatorname{FindRoot} \left(\operatorname{Re} \left(V1 \left(xV1 \cdot \frac{T0}{2} \right) \right); xV1 = 2 \right) = 2$$

Clear(xdV1) = 1

$$LdV1dt := \operatorname{FindRoot} \left(\operatorname{Re} \left(dV1dt \left(xSv1 \cdot \frac{T0}{2} \right) \right); xdV1 = 2,5 \right) = 2,499996353$$

Clear(xV2) = 1

$$LV2 := \operatorname{FindRoot} \left(\operatorname{Re} \left(V2 \left(xV2 \cdot \frac{T0}{2} \right) \right); xV2 = 2,75 \right) = 2,7551180411$$

Clear(xdV2) = 1

$$LdV2dt := \operatorname{FindRoot} \left(\operatorname{Re} \left(dV2dt \left(xSv2 \cdot \frac{T0}{2} \right) \right); xdV2 = 2,5 \right) = \blacksquare$$